



MODEL HONDA CRE F 250 R

YEAR 2011-2012

LINE STRONGER Enduro

MUFFLER OVAL STEEL CARBON CAP

SCHEMATIC

ELENCO PARTI / PARTS LIST

#	QTÀ / QTY	DESCRIZIONE / DESCRIPTION	CODICE / CODE
1	1	DB killer / DB killer	50.DK.069.0
2	1	Rondella M6 / Washer M6	50.73.131.1
3	1	Vite M6 x 8 / Screw M6 x 8	50.72.026.1
4	2	Tappo in gomma / Rubber stopper	50.73.266.1
5	1	Silenziatore INOX / ST.STEEL muffler	OVAL CARBON CAP
6	2	Staffa / Bracket	50.73.386.1
7	4	Dado M5 autobloccante / M5 locknut	50.73.292.1
8	8	Rondella M5 / Washer M5	50.73.351.1
9	1	Staffa / Bracket	50.73.493.1
10	4	Vite M5x25 / Screw M5x25	50.73.392.1
11	1	Distanziale in alluminio / Aluminium spacer	50.SS.454.1
12	2	Boccola in alluminio / Aluminium bush	50.73.381.1
13	2	Silentblock / Silentblock	50.73.380.1
14	2	Rondella M8 / Washer M8	50.73.270.1
15	1	Vite M8x50 / Screw M8 x 50	50.73.391.1
16	1	Vite M8x18 / Screw M8 x 18	50.73.417.1
17	1	Tubo di raccordo / Link pipe	97MHO031LX1FB
18	1	Tubo di raccordo / Link pipe	97MHO031LX1FA
19	2	Dado rapido / Cage nut	50.66.009.1
20	1	Copertura in alluminio / Aluminium cover	50.CR.012.0
21	2	Vite M6 x 12 / Screw M6 x 12	50.72.024.1
22	2	Dado 8 MA flangiato / Flanged nut 8 MA	50.73.393.1
23	1	Flangia / flange	50.73.385.1
24	1	Boccola / Bush	50.73.384.1
25	1	Tiramolla / Spring hook	50.73.395.1
26	5	Molla media / Middle spring	50.73.359.1
27	5	Gommino per molla / Rubber for spring	50.73.210.1

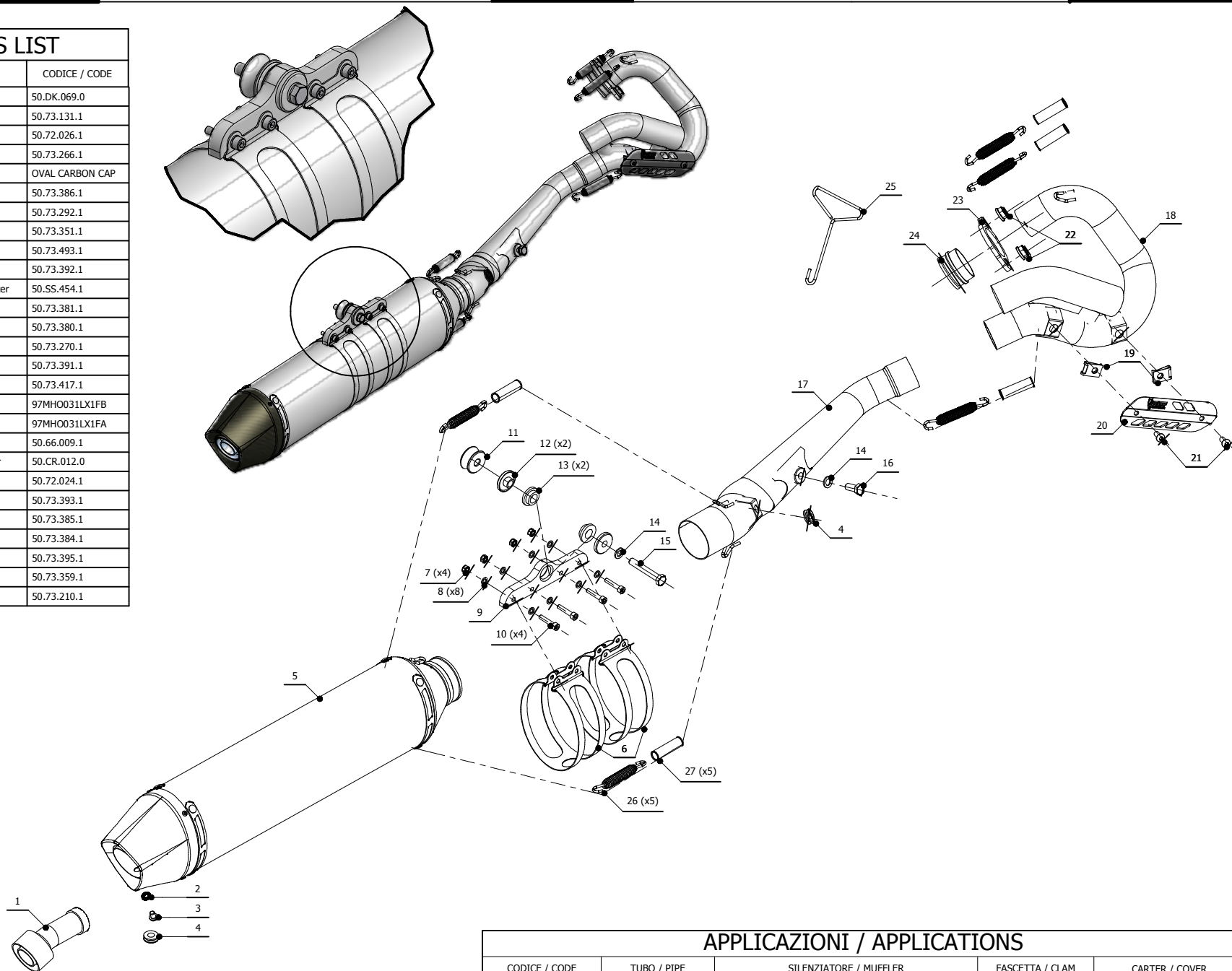

APPLICAZIONI / APPLICATIONS

CODICE / CODE	TUBO / PIPE	SILENZIATORE / MUFFLER	FASCETTA / CLAM	CARTER / COVER
M.HO.031.LXC.F	INOX / ST.STEEL	INOX (COPPA CARBONIO) / ST. STEEL (CARBON CAP)	INOX / ST.STEEL	ALLUMINIO / ALUMINIUM